

## Four Channel Digital Isolators

### Functional Diagram

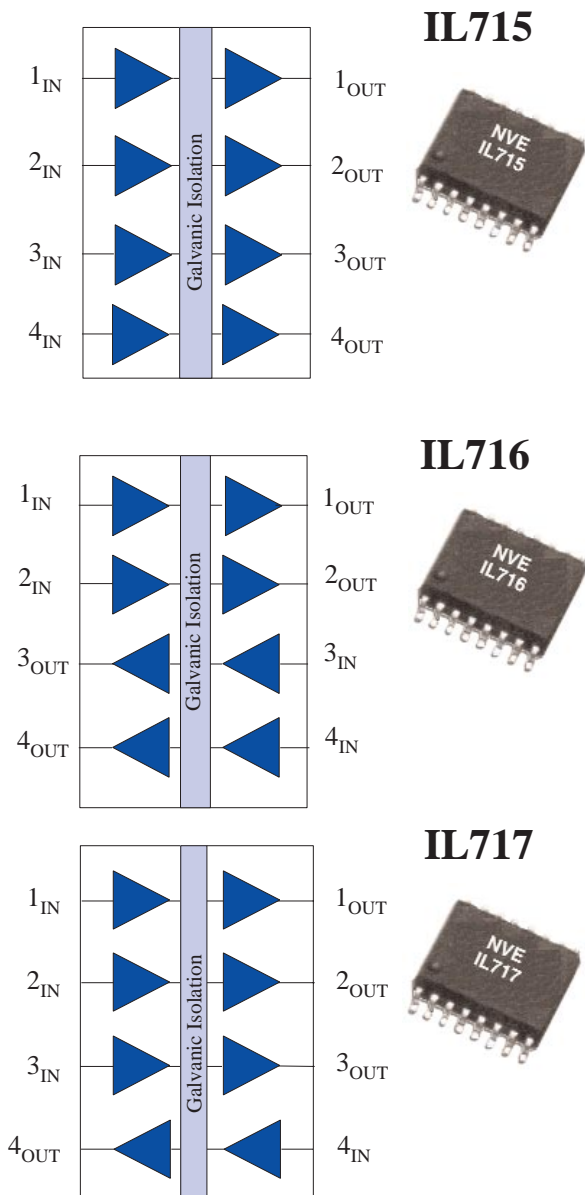

### Features

- +5 and 3.3V CMOS Compatible
- 2500 V<sub>RMS</sub> Isolation (1 min)
- 2 ns Typical Pulse Width Distortion
- 10 ns Typical Propagation Delay
- 30 kV/μs Typical Transient Immunity
- 100 MBd Data Rate
- 16 Pin SOIC Package
- UL1577 Approved (File # E207481)

### Applications

- Isolated Data Transmission
- Isolated ADCs and DACs
- Isolated RS485 and RS422
- Parallel Bus Isolation
- Computer Peripheral Interface Isolation
- Logic Level Shifting

### Description

The IL715, IL716 and IL717 series of 4-channel digital isolators provide the designer with the most compact isolated 5V logic devices yet available. These isolators are packaged in three options: IL715 with four unidirectional channels, IL716 with two channels in one direction and two channels in the opposite direction, and the IL717 with three channels in one direction and one channel in the other direction. All these devices are fabricated with patented\* *IsoLoop*® technology giving them excellent transient immunity specifications. The symmetric magnetic coupling barrier gives these isolators a propagation delay of only 10 ns and a pulse width distortion of 2 ns. Devices are 100% partial discharge tested to guarantee barrier integrity.

The IL715, IL716 and IL717 have a 100 MBaud data rate which is independent of direction. They are available in 16-pin SOIC packages and are specified over the temperature range -40°C to +100°C.

*IsoLoop*® is a registered trademark of NVE, Inc.

\* US Patent number 5,831,426 and others.

# IL715/6/7<sup>IsoLoop®</sup>

## Absolute Maximum Ratings

Parameters	Symbol	Min.	Max.	Units
Storage Temperature	$T_S$	-55	175	°C
Ambient Operating Temperature <sup>(1)</sup>	$T_A$	-55	125	°C
Supply Voltage	$V_{DD1}, V_{DD2}$	-0.5	7	Volts
Input Voltage	$V_I$	-0.5	$V_{DD1}+0.5$	Volts
Output Voltage	$V_O$	-0.5	$V_{DD2}+0.5$	Volts
Output Current	$I_O$		10	mAmps
Lead Solder Temperature (10s)			260	°C
ESD	2kV Human Body Model			

## Insulation Specifications

Parameter	Symbol	Min	Typ.	Max.	Units	Test Conditions
Rated Voltage, 1 minute		2500			$V_{RMS}$	60Hz
Partial Discharge, 100% Tested		2000			$V_{RMS}$	1s, 5pC
Creepage Distance (External)		8.077 (wide body) 4.026 (narrow body)			mm	
Leakage Current			0.1		$\mu$ Amps	240 $V_{RMS}$
Input-Output Momentary <sup>(5,6)</sup> Withstand voltage	$V_{ISO}$	3750			$V_{DC}$	RH<50%, t= 1min, $T_A=25C$
Capacitance (Input-Output) <sup>(5)</sup>	$C_{I-O}$		4.0		pF	f= 1MHz

## Recommended Operating Conditions

Parameters	Symbol	Min.	Max.	Units
Ambient Operating Temperature	$T_A$	-40	100	°C
Supply Voltage	$V_{DD1}, V_{DD2}$	3.0	5.5	Volts
Logic High Input Voltage	$V_{IH}$	$0.8V_{DD}$	$V_{DD}$	Volts
Logic Low Input Voltage	$V_{IL}$	0	0.8	Volts
Input Signal Rise and Fall Times	$t_{IR}, t_{IF}$		1	$\mu$ sec

# IL715/6/7<sup>isoLoop®</sup>

## Electrical Specifications

Electrical Specifications are  $T_{\min}$  to  $T_{\max}$ .

Parameter	Symbol	Min		Typ.		Max.		Units	Test Conditions
DC Specifications		3.3V	5V	3.3V	5V	3.3V	5V		
Input Quiescent Supply Current									
IL715	$I_{DD1}$			17	25	27	40	$\mu\text{A}$	
IL716	$I_{DD1}$			2.4	4	3.3	5	mA	
IL717	$I_{DD1}$			1.5	2.2	1.7	2.5	mA	
Output Quiescent Supply Current									
IL715	$I_{DD2}$			4.8	8	7	10	mA	
IL716	$I_{DD2}$			2.4	4	3.3	5	mA	
IL717	$I_{DD2}$			4.2	7	5.3	8	mA	
Logic Input Current	$I_I$	-10				10		$\mu\text{A}$	
Logic High Output Voltage	$V_{OH}$	$V_{DD}-0.1$ $0.8 \cdot V_{DD}$		$V_{DD}$ $V_{DD}-0.5$				V	$I_O = -20 \mu\text{A}, V_I = V_{IH}$ $I_O = -4 \text{ mA}, V_I = V_{IH}$
Logic Low Output Voltage	$V_{OL}$			0 0.5		0.1 0.8		V	$I_O = 20 \mu\text{A}, V_I = V_{IL}$ $I_O = 4 \text{ mA}, V_I = V_{IL}$
<b>Switching Specifications at 25°C</b>									
Clock Frequency	$f_{\max}$					50	50	MHz	$C_L = 15 \text{ pF}$
Data Rate						100	100	Mbd	$C_L = 15 \text{ pF}$
Minimum Pulse Width	PW	10	10					ns	50% Points, $V_O$
Propagation Delay Input to Output (High to Low)	$t_{PHL}$			12	10	18	15	ns	$C_L = 15 \text{ pF}$
Propagation Delay Input to Output (Low to High)	$t_{PLH}$			12	10	18	15	ns	$C_L = 15 \text{ pF}$
Pulse Width Distortion <sup>(2)</sup> $ t_{PHL} - t_{PLH} $	PWD			2	2	3	3	ns	$C_L = 15 \text{ pF}$
Propagation Delay Skew <sup>(3)</sup>	$t_{PSK}$			4	4	6	6	ns	$C_L = 15 \text{ pF}$
Output Rise Time (10-90%)	$t_R$			2	1	5	3	ns	$C_L = 15 \text{ pF}$
Output Fall Time (10-90%)	$t_F$			2	1	5	3	ns	$C_L = 15 \text{ pF}$
Common Mode Transient Immunity (Output Logic High or Logic Low) <sup>(4)</sup>	$ CM_H $ $ CM_L $	18	20	30	30			kV/ $\mu\text{s}$	$V_{cm} = 300\text{V}$
Channel to Channel Skew	$t_{CSK}$			2	2	3	3	ns	$C_L = 15 \text{ pF}$

## Electrostatic Discharge Sensitivity

This product has been tested for electrostatic sensitivity to the limits stated in the specifications. However, NVE recommends that all integrated circuits be handled with appropriate care to avoid damage. Damage caused by inappropriate handling or storage could range from performance degradation to complete failure.

# IL715/6/7<sup>isoLoop®</sup>

## Notes:

---

1. Absolute Maximum ambient operating temperature means the device will not be damaged if operated under these conditions. It does not guarantee performance.
2. PWD is defined as  $|t_{\text{PHL}} - t_{\text{PLH}}|$ . %PWD is equal to the PWD divided by the pulse width.
3.  $t_{\text{PSK}}$  is equal to the magnitude of the worst case difference in  $t_{\text{PHL}}$  and/or  $t_{\text{PLH}}$  that will be seen between units at 25°C.
4.  $\text{CM}_{\text{H}}$  is the maximum common mode voltage slew rate that can be sustained while maintaining  $V_{\text{O}} > 0.8 V_{\text{DD}}$ .  $\text{CM}_{\text{L}}$  is the maximum common mode input voltage that can be sustained while maintaining  $V_{\text{O}} < 0.8 \text{ V}$ . The common mode voltage slew rates apply to both rising and falling common mode voltage edges.
5. Device is considered a two terminal device:  
pins 1–8 shorted and pins 9–16 shorted.
6. Input–Output Momentary Withstand Voltage is a dielectric voltage and should not be interpreted as an input–output continuous voltage.

## Application Notes:

### Power Consumption

The IsoLoop family of devices achieves its low power consumption from the manner by which it transmits data across its isolation barrier. By detecting the edge transitions of the input logic signal and converting this to a narrow current pulse which drives the isolation barrier, the isolator then latches the input logic state in the output latch. Since the current pulses are narrow, about 2.5 ns wide, the power consumption is independent of mark-to-space ratio and solely dependent on frequency. This has obvious advantages over optocouplers whose power consumption is heavily dependent on its on state and frequency.

### Power Supply Decoupling

Both power supplies to these devices should be decoupled with good quality 47 nF ceramic capacitors. For data rates in excess of 10MBd, use of ground planes for both GND1 and GND2 is highly recommended. Capacitors should be located as close as possible to the device.

### Signal Status on Start-up and Shut Down

To minimize power dissipation, the input signals to the IL715, IL716 and IL717 are differentiated and then latched on the output side of the isolation barrier to reconstruct the signal. This could result in an ambiguous output state depending on power up, shutdown and power loss sequencing. Therefore, the designer should consider the inclusion of an initialization signal in his start-up circuit.

### Data Transmission Rates

The reliability of a transmission system is directly related to the accuracy and quality of the transmitted digital information. For a digital system, those parameters which determine the limits of the data transmission are *pulse width distortion* and *propagation delay skew*.

Propagation delay is the time taken for the signal to travel through the device. This is usually different when sending a low-to-high than when sending a high-to-low signal. This difference, or error, is called pulse width distortion (PWD) and is usually in ns. It may also be expressed as a percentage:

$$\text{PWD}\% = \frac{\text{Maximum Pulse Width Distortion (ns)}}{\text{Signal Pulse Width (ns)}} \times 100\%$$

e.g. for the **IL717** @ 12.5 Mb

$$\text{PWD}\% = \frac{3 \text{ ns}}{80 \text{ ns}} \times 100\% = 3.75\%$$

This figure is almost **3x** better than for any available optocoupler with the same temperature range, and **2x** better than any optocoupler regardless of published temperature range. The *IsoLoop*<sup>TM</sup> range of isolators including the IL717 surpasses the 10% maximum PWD recommended by PROFIBUS, and will run at almost 35 Mb before reaching the 10% limit.

Propagation delay skew is the difference in time taken for two or more channels to propagate their signals. This becomes significant when clocking is involved since it is undesirable for the clock pulse to arrive before the data has settled. A short propagation delay skew is therefore critical, especially in high data rate parallel systems, to establish and maintain accuracy and repeatability. The *IsoLoop*<sup>TM</sup> range of isolators all have a maximum propagation delay skew of 6 ns, which is **5x** better than any optocoupler. The maximum channel to channel skew in the IL717, IL716, and IL715 isolators is only 3 ns which is **10x** better than any optocoupler.

# IL715/6/7 <sup>IsoLoop®</sup>

## Wide Body SOIC-16 Package : Order as IL715, IL716, or IL717

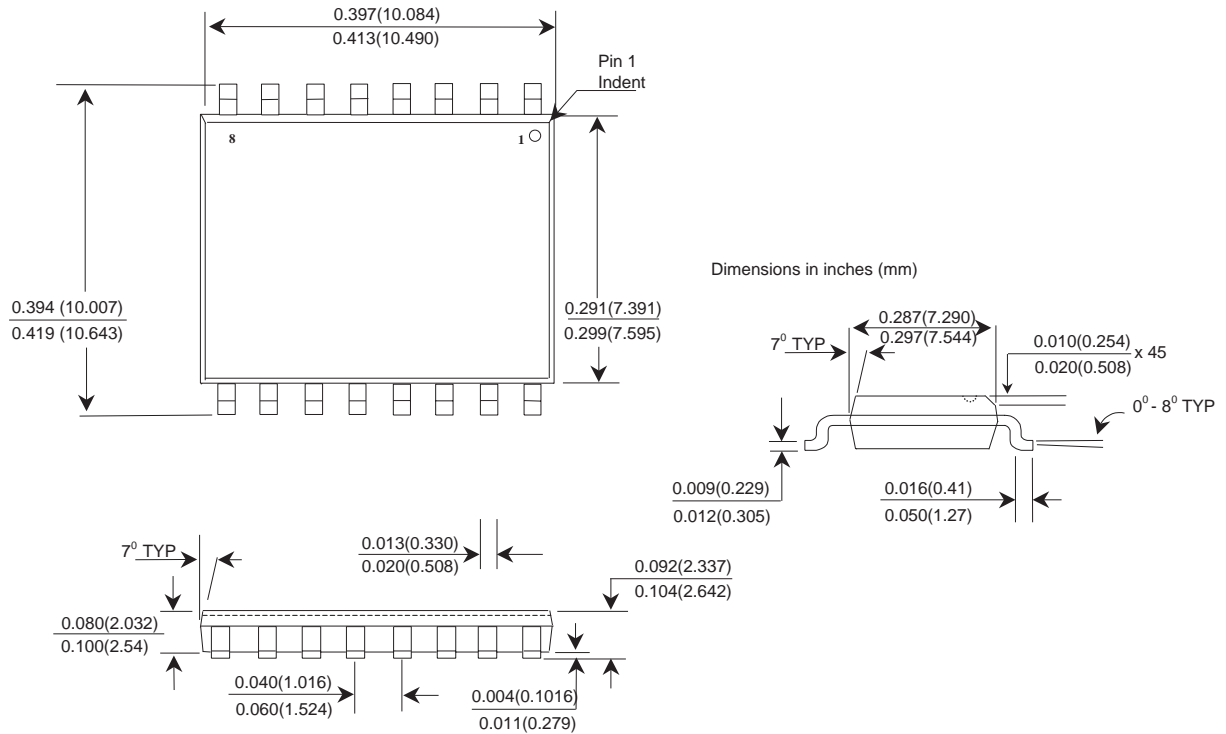

## Narrow Body SOIC-16 Package : Order as IL715-3, IL716-3, or IL717-3

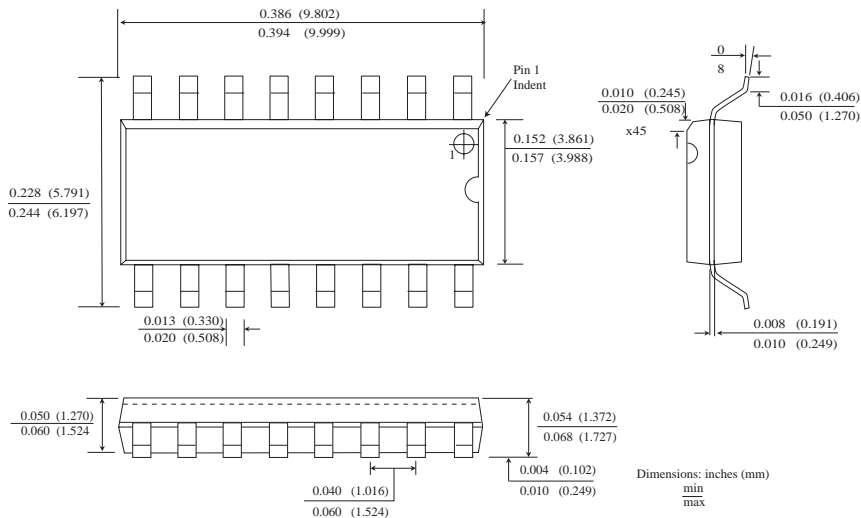

# IL715/6/7<sup>isoLoop®</sup>

## Pin Configurations IL715, IL716, IL717

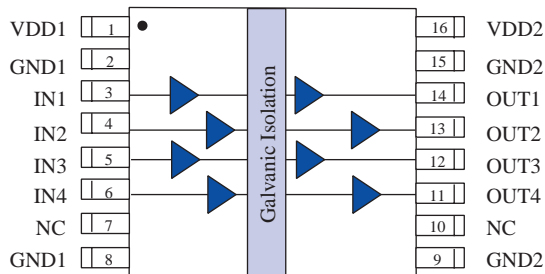

IL715

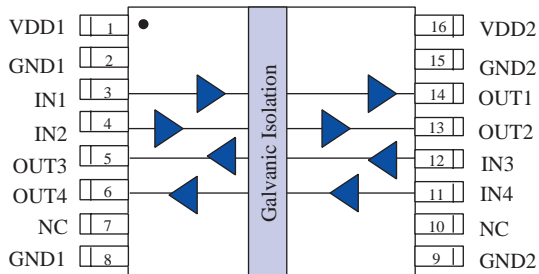

IL716

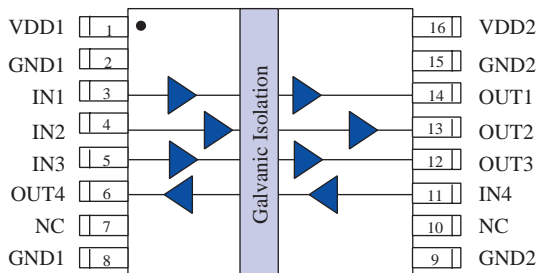

IL717



## About NVE

An ISO 9001 Certified Company

NVE Corporation is a high technology components manufacturer having the unique capability to combine leading edge Giant Magnetoresistive (GMR) materials with integrated circuits to make novel electronic components. Products include Magnetic Field Sensors, Magnetic Field Gradient Sensors (Gradiometer), Digital Magnetic Field Sensors, Digital Signal Isolators and Isolated Bus Transceivers.

NVE is a leader in GMR research and in 1994 introduced the world's first products using GMR material, a line of GMR magnetic field sensors that can be used for position, magnetic media, wheel speed and current sensing.

NVE is located in Eden Prairie, Minnesota, a suburb of Minneapolis. Please visit our Web site at [www.nve.com](http://www.nve.com) or call 952-829-9217 for information on products, sales or distribution.

NVE Corporation  
11409 Valley View Road  
Eden Prairie, MN 55344-3617 USA  
Telephone: (952) 829-9217  
Fax: (952) 829-9189  
Internet: [www.nve.com](http://www.nve.com)  
e-mail: [isoinfo@nve.com](mailto:isoinfo@nve.com)

*The information provided by NVE Corporation is believed to be accurate. However, no responsibility is assumed by NVE Corporation for its use, nor for any infringement of patents, nor rights or licenses granted to third parties, which may result from its use. No license is granted by implication, or otherwise, under any patent or patent rights of NVE Corporation. NVE Corporation does not authorize, nor warrant, any NVE Corporation product for use in life support devices or systems or other critical applications. The use of NVE Corporation's products in such applications is understood to be entirely at the customer's own risk.*

***Specifications shown are subject to change without notice.***

ISB-DS-001-IL715/6/7-B

